

# DSP106II 1.5W-10W ABS Wall Mount Speaker



## Features

- 70/100V, 1.5-10W with multiple terminals
- Max SPL: 100±2dB
- High sensitivity: 92±2dB
- Effective Freq: 160Hz-18kHz
- Made of high quality engineering plastic

## Description

The DSP106II is a wall-mounted speaker with a 70v/100v transformer built in. The 70v/100v transmission is realized in a high-voltage, low-current mode, which makes longer distance transmission and parallel connection of multiple loudspeakers possible.

The max sound pressure level is 100±2dB. Effective Freq range 160Hz-18kHz. Driver surround excellent damping; provided with high sensitivity 92±2dB, long life, with clear and sonorous sound. Equipped with hanging holes for mounting convenient.

It is an ideal choice for industrial and commercial applications in hotel, school, office and factory where background music and paging is needed.

## Specification

<b>Model</b>	<b>DSP 106II</b>
<b>Freq. Resp</b>	160Hz-18kHz
<b>Sensitivity</b>	92±2dB
<b>Max SPL</b>	100±2dB
<b>Weight</b>	1.75kg

## Installation

1. Fit an Ø4mm nail on wall where it is needed to install a speaker system
2. Connect audio broadcasting wire to the terminals according to the table below.

Power Terminals	Line Voltage	70V	100V
Com---3W		1.5W	3 W
Com---6W		3 W	6 W
Com---10W		5 W	10W

3. Position the speaker, then adjust the direction of it and examine whether it is steady.

## Freq. Response

(dB SPL、1W、1m)

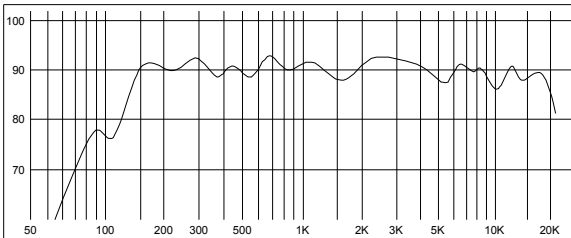

## Distortion

(THD< 1.5% 1W、1m、200Hz-10kHz)

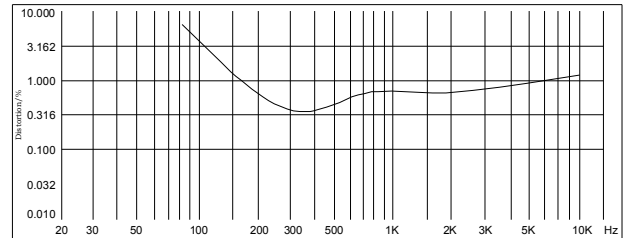

## Hanging Hole

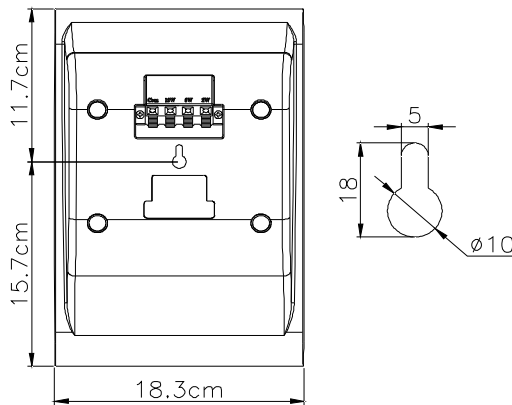

## Nail for Mounting

